

WINTRISS DIE PROTECTION SENSORS



Detect Problems Before Damage Occurs

The DiPro[®] SENSOR INTERFACE (DSI 2) makes it easy to . . .

. . . connect most electronic and electromechanical sensors to your SmartPAC[®] and DiPro 1500. The DiPro Sensor Interface offers:



- Quick-connect plugs for up to eight electronic sensors. Four electromechanical sensors can be used in place of electronic sensors.
- Built-in power supply provides plenty of power for all of your sensing needs.
- LED indicators for each of the eight sensors help in setup and trouble shooting.
- The HD19 or QDP™ Quick Die plugs let you connect up to eight die-mounted sensors to the DSI 2 with one cable. This speeds setup and virtually eliminates errors caused by mis-wiring.
- Built-in pulse stretching on inputs 1-4 allow the die protection control to detect very fast signals (from air ejected parts) that might ordinarily be missed.
- Compact size makes it easy to mount almost anywhere.

Part # 9677901	Part # 9677902	Part # 9677903	Part # 9677908	Part # 9677905	Part # 9677906	Part # 9677907
Front Panel 8 Lumberg SV-40 Bottom No Connector	Front Panel 8 Lumberg SV-40 Bottom HD-19 Connector	Front Panel 8 Lumberg SV-40 Bottom QDP Connector	Front Panel 8 Lumberg SV-40 Bottom QDP and HD-19 Connectors	Front Panel No Connectors Bottom No Connectors	Front Panel No Connectors Bottom HD-19 Connector	Front Panel No Connectors Bottom QDP Connector

SPECIFICATIONS: DiPro Sensor Interface (DSI 2)

SENSOR TYPE	NPN, PNP, 2-wire DC, Electromechanical
SENSOR CONNECTIONS	Power, Common and Signal
MAX. NUMBER OF SENSORS	8 electronic or 4 electronic and 4 electromechanical
INPUT POWER REQUIREMENTS	100-240 VAC, 50/60 Hz, 20 VA, max.
INPUT VOLTAGE WITH SENSOR ACTUATED	All inputs: NPN - 3 volts max.; PNP - 21 volts, max.
INPUT CURRENT WITH SENSOR OFF	2 mA, max.
OUTPUT VOLTAGE/CURRENT TO SENSORS	24 VDC ±5% / 1/2 A, max.
OUTPUT SIGNALS TO DIE PROTECTION CONTROL	NPN only
LED INDICATORS	Sensor output and power on
OPERATING TEMPERATURE	32° to 122° F (0° to 50° C)
PULSE STRETCHING INPUTS	Inputs 1-4 (approx. 10 ms)
QUICK-CHANGE SENSOR CONNECTORS	Eight 4-pin locking plugs (Lumberg SV-40 or equiv.); 12-pin QDP locking plug (Lumberg SV-120 or equiv.); HD19 19-pin connector (RDE UC-19S1N1280DU or equiv.); Knock-out for other types of connectors

WINTRISS SENSORS FOR DIE PROTECTION: Photoelectric, Fiberoptic, and Proximity

Wintriss Controls Group offers a complete line of die protection sensors for in-die use. These sensors are rugged, shock resistant, and sealed against the environment. Sensors are available to detect everything from end of coil, to misfeed, to part ejection.

PHOTOELECTRIC SENSORS

Photosensors consist of an emitter and receiver in either separate housings (through-beam photosensors) or in a common housing (reflective photosensors). The emitter converts electrical energy into light; the receiver detects the light from the emitter and sends an electrical signal to the die protection control.

Photosensors operate in the light-on or dark-on mode. In the light-on mode, the sensor actuates (turns on) when light from the emitter reaches the receiver. In the dark-on mode, it actuates when the receiver does not detect light from the emitter.

The operating mode for most photosensors is switch selected; some must be wired to operate in either light-on or dark-on mode.

Diffuse and retroreflective sensors have built-in cross-talk prevention that allows sensors to be installed close to each other without mutual interference.

FIBEROPTIC SENSORS

A fiberoptic sensor is made up of a light source and a fiber. The light source contains the emitter and receiver as well as a sensitivity adjustment and light-on/dark-on selector switch.

The fiberoptic fiber(s) attach to the light source via a convenient cam-lock mechanism. Fiberoptic sensors are offered in two configurations: opposed and reflective. Wintriss Controls Group uses Armored Tough Flex fibers that come pre-cut to a specific length of 39 inches (1 meter). A stainless steel flexible jacket protects the fiber from premature breakage due to daily wear and tear that is often found in a stamping environment. Lens attachments are also available to extend the range when using opposed beam fibers.

INDUCTIVE PROXIMITY SENSORS

Inductive proximity sensors can detect, without physical contact, the presence of a metallic object. When power is applied to the sensor, an invisible sensing field emanates

from the face of the sensor. A metallic object entering this field is detected by the sensor.

The proximity sensors offered by Wintriss Controls Group are excellent sensors for in-die use. Sensing ranges and operating characteristics are unaffected by lubricants and other non-metallic contaminants. In addition, proximity sensors are the most accurate sensors commonly used

for die protection. With trip-point repeatability as small as 0.0004 in (0.01 mm), they are more than accurate enough for detecting die malfunctions.

SENSING DISTANCE VS. MATERIAL COMPOSITION

Proximity sensors' sensing distance specifications are based on the sensor detecting a "standard target" made of mild steel. To find the correct sensing distance for a material other than mild steel, multiply the specified sensing distance by the material correction factor from the table above.

Proximity sensors sold by Wintriss Controls Group are shielded so they can be flush mounted in metal. Although shielded sensors can be flush mounted, it is good practice to install the sensors

slightly recessed to help protect the sensor face. The sensor face is made of either plastic or epoxy, and should not be subjected to wear. This is especially important for sensors installed in the lower die to detect an edge or holes in the strip. Proximity

MATERIAL	CORRECTION FACTOR
Mild Steel	1.00
Stainless Steel	0.85
Aluminum	0.40
Brass	0.30
Copper	0.30

sensors are available with either normally open or normally closed outputs. Normally closed sensors actuate in the presence of metal; normally open sensors actuate when no metal is present, and are used for detecting holes.

For more detailed information on electronic sensors and die protection in general, we recommend the Wintriss Die Protection Handbook. The handbook contains over 130 pages (and 150 illustrations) packed with information on die protection theory, sensors, applications, and die wiring. To automatically receive updates, you may register your copy of the Handbook. Updates include new applications, sensor information, and tips on proper use and installation of sensors.

SENSOR CONNECTION HARDWARE:

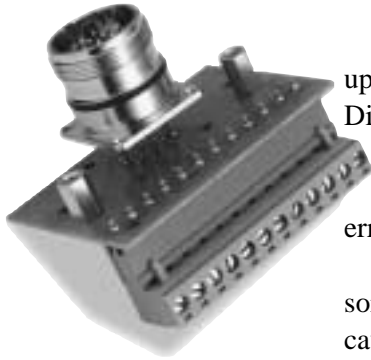

The **HD19 Kit** enables you to connect up to eight die-mounted sensors to your DiPro Sensor Interface with one heavy-duty cable, reducing setup time and virtually eliminating sensor wiring errors during setup.

The HD19 kit also helps to extend sensor life by eliminating the number-one cause of sensor failure: damaged cables.

When die-mounted sensors have to be plugged into a press-mounted interface box, it is necessary to keep long sensor cables coiled up on the die. Often, these cables are damaged while the die is being handled. With the HD19 Kit, the

main cable stays with the press, and sensor cables on the die are kept as short as possible. The HD19 Kit is designed to be installed in a user-supplied, die-mounted enclosure. The kit consists of a circuit board with a 19-pin heavy-duty connector on one side and a terminal strip with removable connector on the other side. Cables are available in three lengths and must be ordered separately.

For added convenience and simplicity, another option is the **HDP** (Heavy Duty Plug). This is a hermetically sealed junction box that can be mounted directly on or near the die without the need for a PC board or enclosure. It's available in either a 4 or 8 port configuration and can only be used with HD19

cables. Sensors plug directly into the HDP using either a straight or 90-degree mating connector.

The **QDP Kit** looks and works just like the HD19 Kit, except its cables and connectors are not as heavy duty. It's ideal for applications where cost is a factor or when die changes are less frequent and activity around the press or die is limited. The QDP Kit consists of a PC board, 12-

pin connector and removable terminal strip. It is designed to be mounted in a user-supplied die-mounted enclosure. QDP Cables are available in three lengths, and must be ordered separately.

QDP Kit and Cables

QDP Kit	Part # 4268901
QDP Cable - 5 ft (1.52 m)	Part # 4268801
QDP Cable - 10 ft (3.05 m)	Part # 4268802
QDP Cable - 15 ft (4.57 m)	Part # 4268803

HD19 Kit and Cables

HD19 Kit	Part# 4268902
HD19 Cable - 5 ft (1.52 m)	Part# 4310801
HD19 Cable - 10 ft (3.05 m)	Part# 4310802
HD19 Cable - 15 ft (4.57 m)	Part# 4310803



Heavy Duty Plugs (HDP)

Heavy Duty Plug - 4-port	Part# 4310601
Heavy Duty Plug - 8-port	Part# 4310603

Mating Connectors for Heavy Duty Plugs (HDP)

Mating Connector - Straight	Part# 2269201
Mating Connector - 90°	Part# 2269202

The **Remote Connection Box** is an economical alternative to the DiPro Sensor interface for dedicated or secondary stamping operations where sensor use is limited.

The Remote Connection Box has three quick-connect plugs for electronic sensors and six jacks for electromechanical sensors.

The RCB has no internal power supply so the power available for electronic sensors is limited by the die protection control the RCB is connected to. The SmartPAC and the DiPro 1500 each have 100 mA available to the RCB. This is enough to power three typical electronic sensors.

Remote Connection Box

With Cable - 30 ft (9.1 m)	Part # 4235701
With Cable - 100 ft (30.5 m)	Part # 4235702

Extra Sensor Connectors for connecting non-Wintriss sensors to the DSI 2 or RCB. Connectors with banana jacks make it possible to connect more than 4 electro-mechanical sensors to the DSI 2.

Extra Sensor Connectors

Lumberg SV-40	Part # 2191701
Lumberg SV-40 with banana jack	Part # 4217701



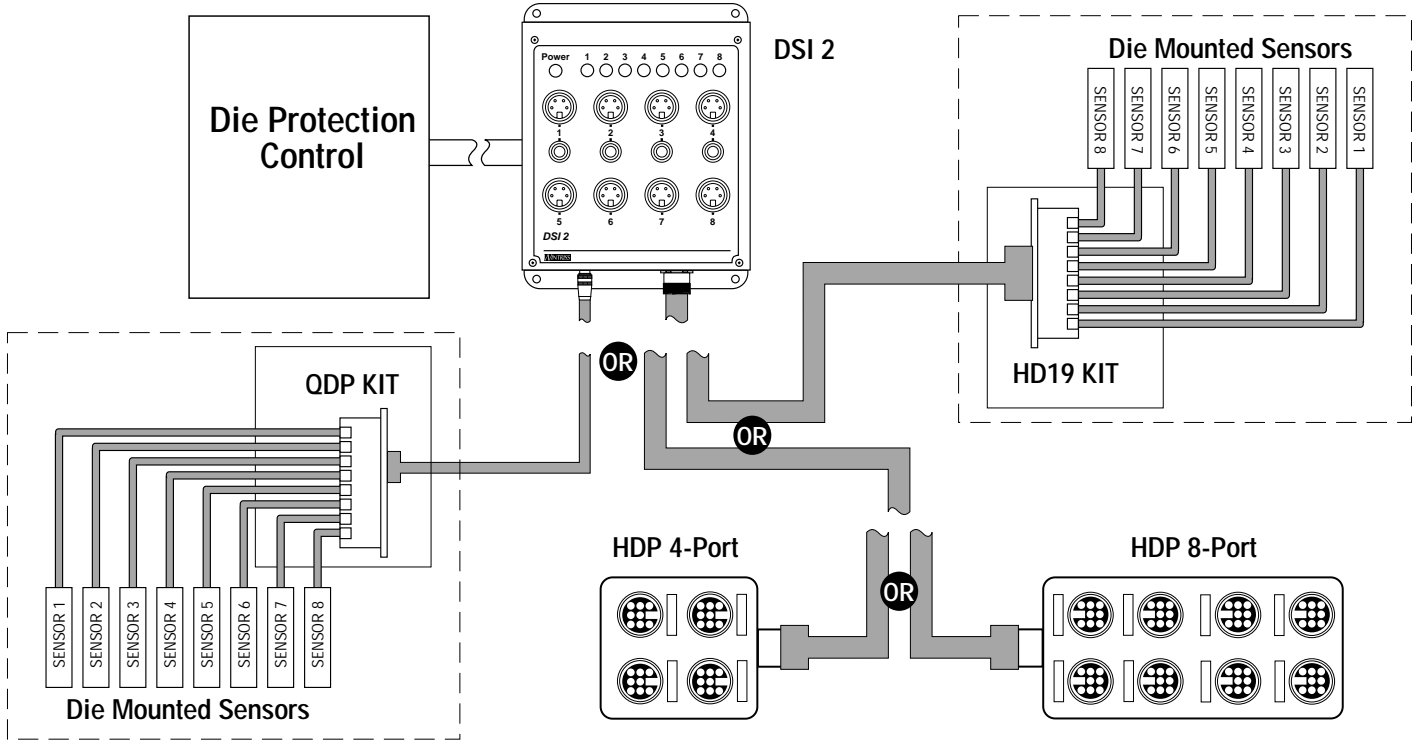

DIMENSIONS: QDP and HD-19

QDP

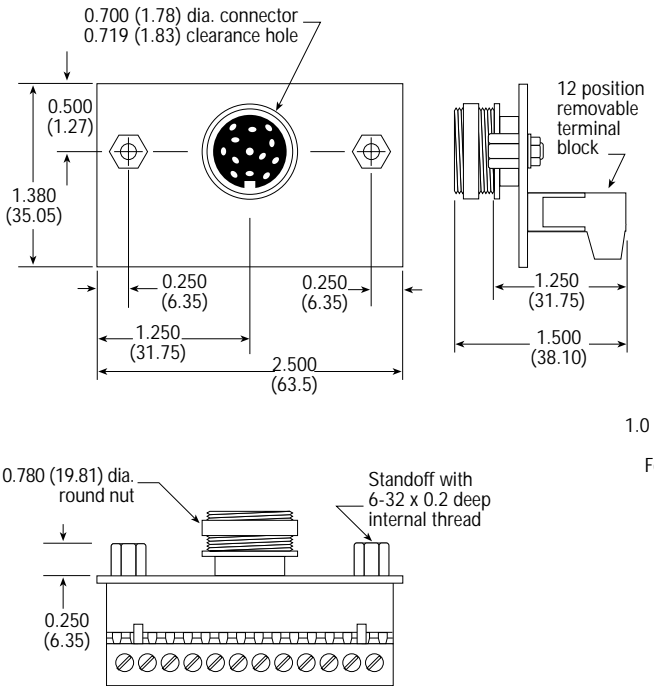

HD-19

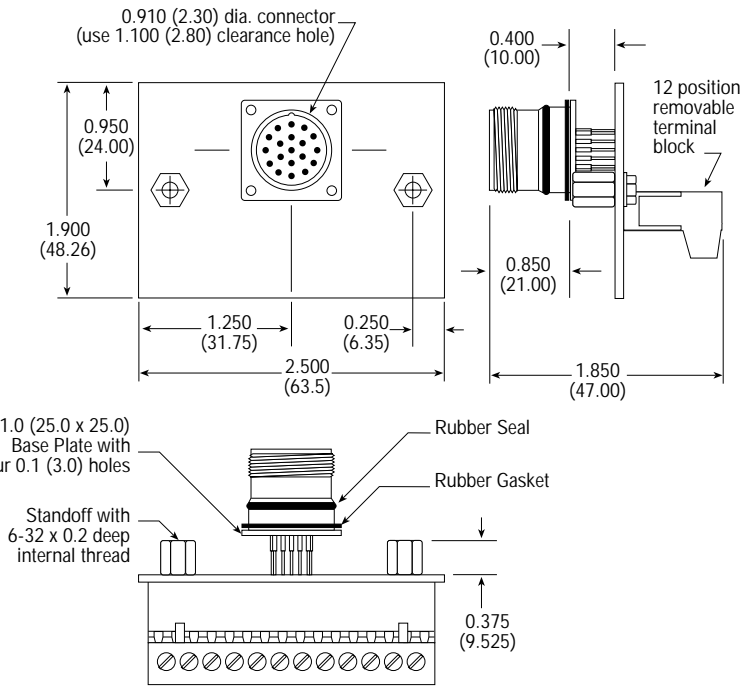

Dimensions: inches (millimeters)

PHOTOELECTRIC SENSORS

Diffuse Reflective Sensors are primarily used to detect part ejection. These sensors are extra sensitive, so they can be used for detecting small, fast-moving parts. Care should be taken when installing diffuse reflective sensors to ensure that background objects do not cause accidental actuation.

Diffuse Reflective Sensors, CX-24 (short range)

With quick-connect plug	Part# 4288202
Without plug	Part# 2249303

Diffuse Reflective Sensors, CX-22 & PZ41 (long range)

CX-22	
With quick-connect plug	Part# 4288201
Without plug	Part# 2249302

PZ-41

With quick-connect plug (light-on only)	Part# 4223001
Without plug	Part# 2199601

Use the short-ranged CX-24 for applications where the part passes close to the sensor and where maximum background suppression is required. Use the longer range CX-22 or PZ-41 for general part ejection detection. All sensors use infrared light to minimize false actuations caused by oil in the sensing field.

Retroreflective Sensors are reflective sensors that use a reflective target (included) to establish a sensing beam.

The CX-29 sensor has a 10 ft (3.05 m) maximum sensing range. When installed with the sensor and reflector less than 10 ft (3.05 m) apart, the unused range (also called the “excess gain”) provides extra power to enable the sensor to shine right through lubricant and other contaminants.

The sensor and reflector feature built-in polarizing filters to allow the sensor to detect even very reflective parts.

Retroreflective sensors are most often used in the dark-on mode (part breaks the beam to actuate the sensor). However, the CX-29 has a light-on/dark-on selector switch.

Retroreflective Sensor, CX-29

With quick-connect plug	Part# 4288203
Without plug	Part# 2249304

Through-Beam Photosensor is a general-purpose photosensor with separate emitter and receiver. The CX-21 has a long range, 33 ft (11.48 m). When this sensor is installed with the emitter and receiver less than 33 ft (11.48 m) apart, the unused range (also called the “excess gain”) provides enough power to

enable the sensor to shine right through lubricant and other contaminants.

The CX-21 has a switch to select light-on or dark-on operating mode. Use the dark-on (beam break) mode for

detecting part or slug ejection, or shortfeed. Use the light-on (beam make) mode for detecting a hole in the strip. The CX-21 uses infrared light.

An optional aperture kit with two apertures (one for the emitter and one for the receiver) is available for use in tight-clearance applications such as slug detection, or when a more precise beam is required to detect smaller parts or features.

Through-Beam Photosensor, CX-21

With quick-connect plug	Part# 4288301
Without plug	Part# 2249301
Aperture kit	Part# 9613105

SPECIFICATIONS: Photoelectric Sensors

MODEL	CX-21	CX-22	CX-24	CX-29	PZ-41
SENSING MODE	Through-Beam	Diffuse Reflective	Diffuse Reflective	Retroreflective	Diffuse Reflective
SENSING RANGE	33.0 ft (10.1 m)	2.6 ft (0.8 m)	1.0 ft (0.3 m)	10.0 ft (3.0 m)	2.0 ft (0.6 m)
PART # WITH PLUG	4288301	4288201	4288202	4288203	4223001
PART # WITHOUT PLUG	2249301	2249302	2249303	2249304	2199601
POWER SUPPLY	12-24 Volts DC	12-24 Volts DC	12-24 Volts DC	12-24 Volts DC	12-24 Volts DC
REQUIREMENTS	Emitter and Receiver each 30 mA, max.	35 mA, max.	35 mA, max.	35 mA, max.	30 mA, max.
RESPONSE TIME	1 msec max.				
OUTPUT	NPN Open Collector, max. 100 mA				
OUTPUT MODE	Light-On / Dark-On Switch Selectable (PZ-41 with quick-connect plug is light-on only)				
OUTPUT INDICATORS	Red LED turns ON when sensing output is ON				
PROTECTION RATING	IEC IP67				

DIMENSIONS: Photoelectric Sensors

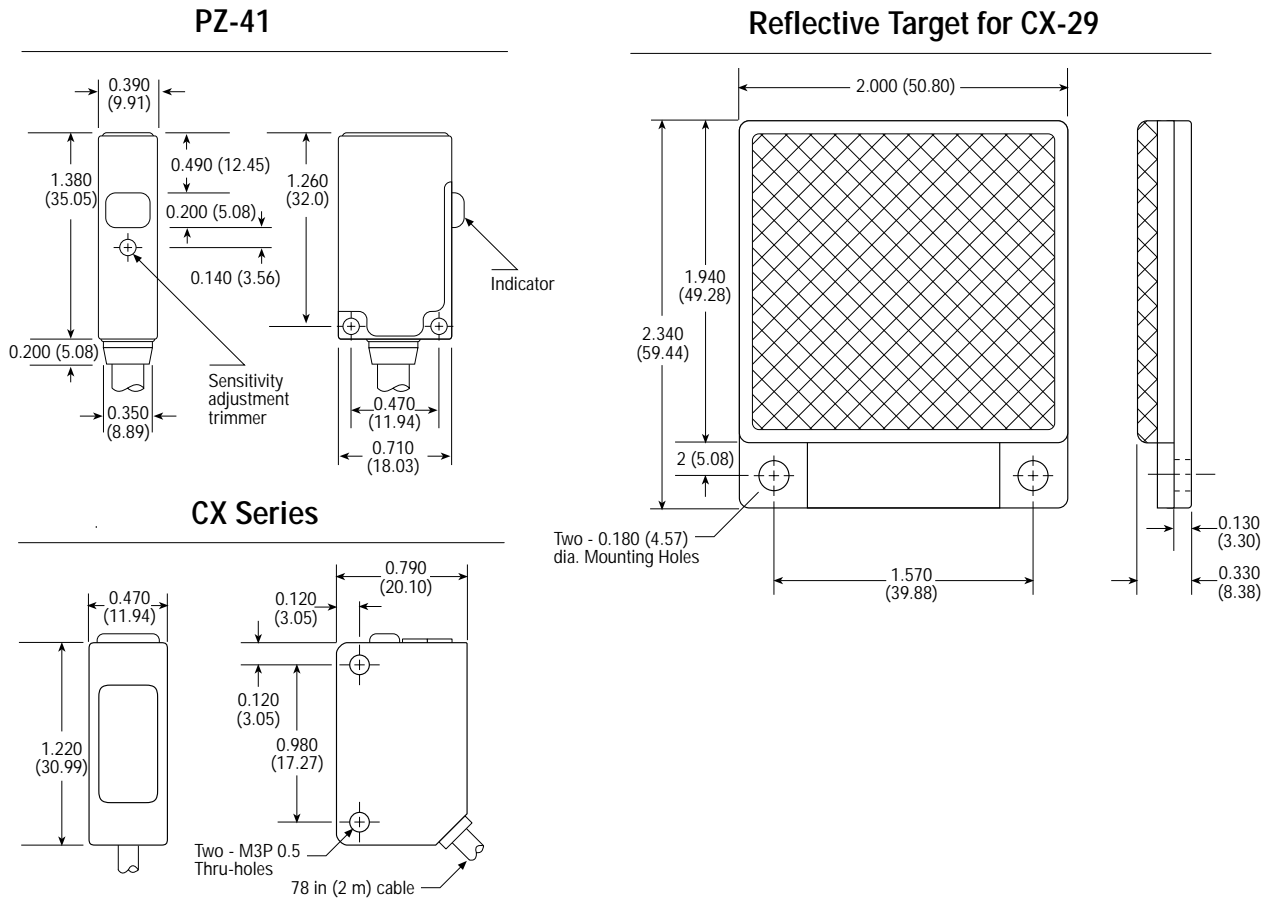

NOTE: Dimensions are the same for the emitter and receiver of the through-beam CX-21

Dimensions: inches (millimeters)

PHOTOELECTRIC SENSORS *continued*

Optical Convergent Sensors are reflective photo-sensors with the emitter and receiver in the same housing. The MQ-W20 has three beams (one emitter and two receivers), and uses triangulation to set a precise actuation point (focal area) at an adjustable distance in front of the sensor. Any object outside of the focal area, whether it is closer or more distant, is ignored.

The MQ-20W features a rugged, die-cast metal housing, with a detecting range of 1 to 8 in. (25.4 to 203.2 mm). It can be used for detecting parts on a conveyor, blanks sliding down a chute, or anywhere a precise reflective photo-sensor is needed.

MQ-W20 (1 to 8 inch range)

With quick-connect plug	
Light-on	Part# 4274801
Dark-on	Part# 4274901
Without plug	Part# 2238601

A **Photoelectric Fork Sensor** is a through-beam photosensor with a prealigned emitter and receiver permanently housed in a U-shaped cast metal case. The sensor's resemblance to a tuning fork gives it its name.

Used primarily for short-feed detection, the RT-610-50 is typically installed at the end of the die to detect either a hole or the edge of the strip.

The RT-610-50 is available in a light-on version for hole detection, a dark-on version for edge detection, and without a connector for use with the HD19 or QDP kits.

RT-610-50

With quick-connect plug	
Light-on	Part# 4288401
Dark-on	Part# 4288501
Without plug	Part# 2249401

A FEW TIPS WHEN USING THESE SENSORS:

- You can make your own apertures for through-beam photosensors using shim stock. Just drill the appropriately sized hole and install the shim in front of the emitter, receiver, or both.
- An aperture effect can be achieved by slightly misaligning the emitter and receiver of a through-beam photosensor.
- When installing two through-beam photosensors next to each other, place the emitter of one sensor next to the receiver of the other. This prevents crosstalk between the sensors.
- When using a fork sensor to detect the edge of a part that is then cut off, you should take steps to prevent the part from hitting the lens of the fork sensor. These lenses are made from tough plastic, but they are no match for a sharp burr on a metal part. One way to protect the lens is to install a ramp inside the fork sensor to divert the part away from the lens. If necessary, drill a hole in the ramp to allow the sensing beam through.

SPECIFICATIONS: Photoelectric Sensors

MODEL	RT-610-50	MQ-W20A
SENSING MODE	Through-Beam Fork Sensor	Optical Triangulation
SENSING RANGE	2 in. (50.8 mm) (fixed)	1-8 in. (25.4 to 203.2 mm)
PART # LIGHT-ON	4288401	4274801
PART # DARK-ON	4288501	4274901
PART # DARK-ON WITHOUT CONNECTOR	2249401	2238601
POWER SUPPLY	12-24 Volts DC	12-24 Volts DC
REQUIREMENTS	40 mA, max.	30 mA, max.
RESPONSE TIME	2 msec max.	
OUTPUT	Light-On / Dark-On Mode Selectable by Wiring	
OUTPUT MODE	NPN Open Collector, max. 100 mA	
OUTPUT INDICATORS	Red LED turns ON when sensing output is ON	
PROTECTION RATING	IEC IP66	IEC IP67

DIMENSIONS: Photoelectric Sensors

RT-610-50 FORK SENSOR

MQ-W20 OPTICAL TRIANGULATION SENSOR

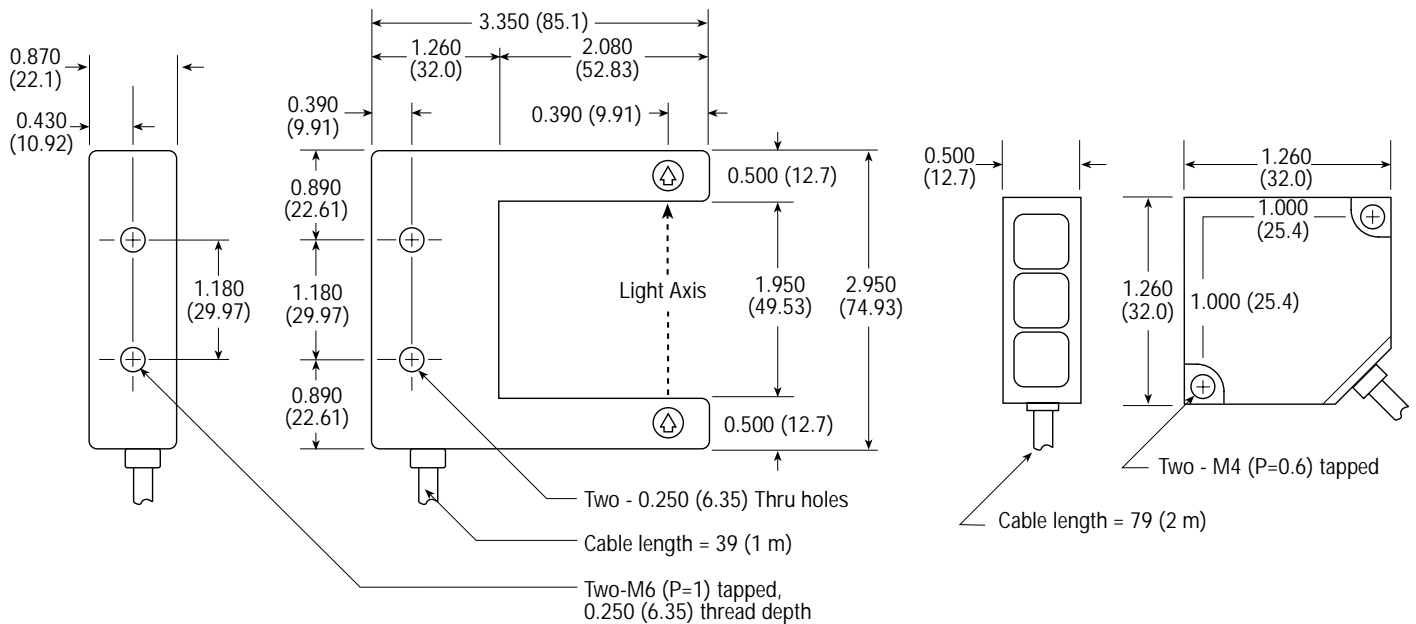

Dimensions: inches (millimeters)

FIBEROPTIC SENSORS

Fiberoptic Light Source: The FS-V11 is a hybrid digital amplifier that delivers both high accuracy and high power. It is packed with many features and functions, while other advanced fiberoptic sensors provide only one or two. Three levels of detection, Super, Turbo, and Fine, make it versatile enough for most applications. Detecting distances are push-but-

ton selectable and are easily identified by LED indicators on the amplifier's LED Bar graph. A Dual Monitoring system allows for simplified status checking. Either a digital LED

indicator numerically displays the received light intensity or a bar LED indicator shows the level of the detection stability (excess gain). The digital LED indicator can be used to align the optical axis and to display operating conditions during mounting; the bar LED indicates the detection stability during operation. Calibration is fully automatic using the Automatic Set button, or fine adjustments can be made using the Manual button. After a quick adjustment in the Auto mode, detection can begin and any fine adjustments can be made using the Manual button. There is no need for complicated and time-consuming tweaking of small hard-to-see trimming pots.

Even the most inexperienced users will be able to make precise adjustments with the simple push of a button either automatically or manually. Bar LED indicators identify unstable operations at a glance. A stable detection is achieved when all LEDs are lit during light beam reception and off when the light beam is interrupted. Other fea-

tures include a light-on or dark-on mode selector switch, red LED visible light output and a 500 μ s response time (Turbo Mode). Only one amplifier is needed and can be interchanged with either of the fibers on this page. Light sources are not environment-proof, if they are to be installed on or in the die, it is best to use the enclosure listed to left.

Fiberoptic Fibers are available in two types and models, Reflective (FU-67G) or Through-Beam (FU-77G)

Reflective Fiberoptic Fibers have the emitting and receiving fibers in a common fiber bundle. They actuate when light reflects off the target object. Through-Beam Fiberoptic Fibers use separate emitting and receiving fibers. These are excellent when clearances are too tight for a through-beam photosensor.

They both feature a new Armored Tough Flex stainless steel protective jacket. Tough Flex fibers are strong yet flexible and will not break even when sharply bent. They are shock resistant and will continue to perform even when accidentally dropped or struck by a tool. Ready for immediate use, Armor Tough Fibers provide cost savings by eliminating the need for protective tubing. Both fibers come with threaded tips (hardware included) for convenient mounting and are factory-cut to a length of 3.280 ft (1 m). A locking cam mechanism makes it easy to plug fibers into the FS-V11 light source. Detecting distances vary for either model depending on the mode selected on the Light Source. The FU-67G Reflective Fiber has a detecting range of 2.560 in. (65 mm) Fine Mode to 7.090 in. (180 mm) Super Mode. The FU-77G Through-Beam Fiber has a detecting range of 9.060 in. (230 mm) in the Fine Mode to 22.440 in. (570 mm) in the Super Mode. If extended range is needed, the F2 lens attachment will increase the FU-77G's detecting distance up to 11.81 ft (360 m).

FS-V11 (general purpose digital amp.)

With quick-connect plug	Part # 4223501
Without plug	Part # 2149901
Enclosure	Part # 9611702

FU 67G

Reflective - (3 ft) 1 m	Part # 2149801
-------------------------	----------------

FU 77G

Through-Beam - (3 ft) 1 m	Part # 2149802
---------------------------	----------------

F2 LENS ATTACHMENT (Fits FU-77G)

Increase Detecting Distance (1500 - 3600 mm)	Part # 2199708
--	----------------

SPECIFICATIONS: Light Source

MODEL	FS-V11
LIGHT SOURCE	Red LED
RESPONSE TIME	250 μ s (fine) / 500 μ s (turbo) / 1 ms (super turbo)
OPERATION MODE	Light-On / Dark-On (switch selectable)
OUTPUT INDICATOR	Red LED (turns ON when output is on the ON state)
DIGITAL LED INDICATOR	Red LED (normally displays the received light intensity)
BAR GRAPH LED INDICATOR	Green/Orange LED (shows the level of detection stability - excess gain)
CALIBRATION INDICATOR	Orange LED
TIMER FUNCTIONS	OFF-delay: 40 ms, 10 ms/Timer OFF (switch selectable)
CONTROL OUTPUT	NPN or PNP open-collector: 100 mA (40 V, max.) Residual voltage: 1 V, max.
PROTECTION CIRCUIT	Reverse polarity protection, Over-current protection, Surge absorber
POWER SUPPLY VOLTAGE	12 to 24 VDC \pm 10%, Ripple (P-P) 10%, max.
CURRENT CONSUMPTION	50 mA, max.
AMBIENT ILLUMINATION	Incandescent lamp: 10,000 lux, max., Sunlight: 20,000 lux, max.
AMBIENT TEMPERATURE	-10 C° to +55 C°
RELATIVE HUMIDITY	35% to 85%
VIBRATION	10 to 55 Hz, 1.5 mm double amplitude in X, Y and Z for two hours
SHOCK IMMUNITY	500 m/s ² in X, Y and Z directions, three times each
HOUSING MATERIAL	Body/Cover: Polycarbonate
WEIGHT (including 2m cable)	Approx. 80 g

SPECIFICATIONS: Fiberoptic Fibers

MODEL	
FU-77G	Thrubeam (Max. Distance) - Super: 22.440 in. (570 mm) Turbo: 14.110 in. (460 mm) Fine: 9.060 in. (230 mm)
FU-67G	Reflective (Max. Distance) - Super: 7.090 in. (180 mm) Turbo: 5.120 in. (130 mm) Fine: 2.560 in. (65 mm)

DIMENSIONS: Light Source and Fiberoptic Fibers

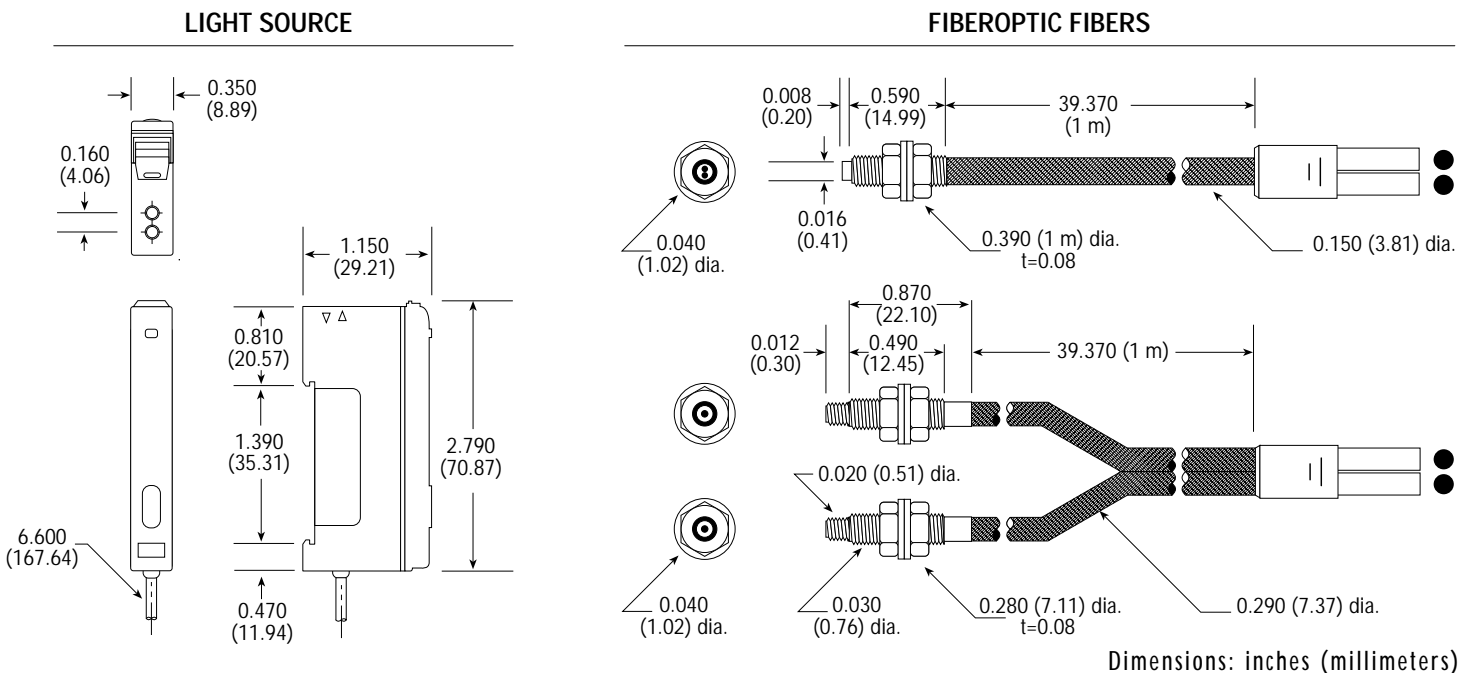

SELF CONTAINED PROXIMITY SENSORS

Self-Contained Proximity Sensors

require no external amplifier and are available in 5 sizes to fit a variety of applications. These sensors are shielded so they can be flush mounted in the die.

The five available sensors are as follows:

3 mm sensor: *0.020 in. (0.6 mm) range (non-threaded body)* This sensor is precise enough to detect stripper position at BDC to within 0.001 in. (0.025 mm), or detect holes as small as 0.020 in. (0.51 mm).

8 mm sensor: *0.060 in. (1.5 mm) range (M8 threaded body)*. This is a general purpose sensor for detecting feed, transfer, cam return, etc.

12 mm sensor: *0.100 in. (2.5 mm) range (M12 threaded body)* This is a general purpose sensor for detecting feed, transfer, cam return, etc.

18 mm sensor: *0.200 in. (5 mm) range (M18 threaded body)*. This is a general purpose sensor for detecting feed, transfer, cam return, etc.

30 mm sensor: *0.400 in. (10 mm) range (M30 threaded body)*. This sensor is usually used to detect buckle, or end of stock, or can be mounted in a chute to detect part ejection.

Sensors are available with or without a quick-connect plug on the cable. The P&F-3, P&F-8 and P&F-30 mm sensors are only available with normally open outputs. The EZ-8, EZ-12, P&F-12 and P&F-18 mm sensors are available with either normally open or normally closed outputs.

P&F-3 mm Diameter/Detecting distance = 0.020 in. (0.60 mm)

Normally Open	
With quick-connect plug	Part # 4292301
Without plug	Part # 2252201

P&F-8 mm Diameter/Detecting distance = 0.060 in. (1.50 mm)

Normally Open	
With quick-connect plug	Part # 4292401
Without plug	Part # 2252301

EZ-8 mm Diameter/Detecting distance = 0.060 in. (1.50 mm)

Normally Open	
With quick-connect plug	Part # 4222801
Without plug	Part # 2199501
Normally Closed	
With quick-connect plug	Part # 4283301
Without plug	Part # 2199501

P&F-12 mm Diameter/Detecting distance = 0.100 in. (2.50 mm)

Normally Open	
With quick-connect plug	Part # 4292402
Without plug	Part # 2252302
Normally Closed	
With quick-connect plug	Part # 4292802
Without plug	Part # 2252702

EZ-12 mm Diameter/Detecting distance = 0.100 in. (2.50 mm)

Normally Open	
With quick-connect plug	Part # 4222802
Without plug	Part # 2199502
Normally Closed	
With quick-connect plug	Part # 4283302
Without plug	Part # 2199502

P&F-18 mm Diameter/Detecting distance = 0.200 in. (5.00 mm)

Normally Open	
With quick-connect plug	Part # 4292403
Without plug	Part # 2252303
Normally Closed	
With quick-connect plug	Part # 4292803
Without plug	Part # 2252703

P&F-30 mm Diameter/Detecting distance = 0.400 in. (10.00 mm)

Normally Open	
With quick-connect plug	Part # 4292404
Without plug	Part # 2252304

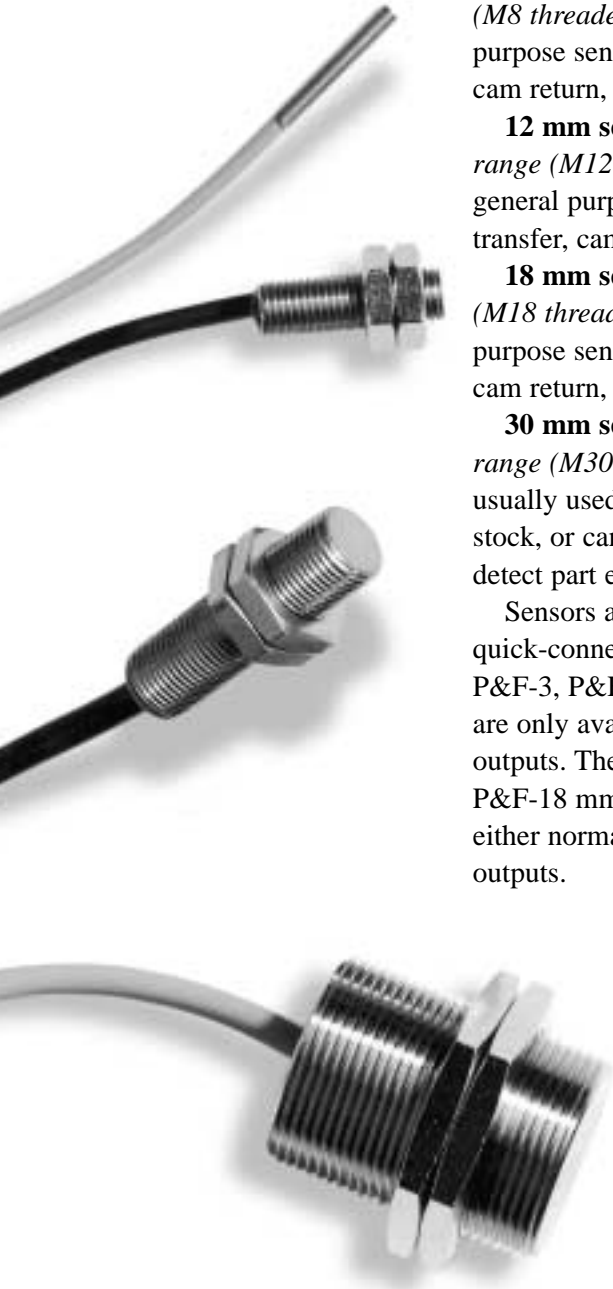

SPECIFICATIONS: Self Contained Proximity Sensors

MODEL	P&F-3M	P&F-8M	EZ-8M	P&F-12M	EZ-12M	P&F-18M	P&F-30M
N/O WITH PLUG	4292301	4292401	4222801	4292402	4222802	4292403	4292404
N/O WITHOUT PLUG	2252201	2252301	2199501	2252302	2199502	2252303	2252304
N/C WITH PLUG	CALL US	CALL US	4283301	4292802	4283302	4292803	CALL US
N/C WITHOUT PLUG	CALL US	CALL US	2199501	2252702	2199502	2252703	CALL US
DETECTING DISTANCE	0.020 in. (0.60 mm)	0.060 in. (1.50 mm)	0.060 in. (1.50 mm)	0.100 in. (2.50 mm)	0.100 in. (2.50 mm)	0.200 in. (5.00 mm)	0.400 in. (10.00 mm)
REPEATABILITY	0.0004 in. (0.01 mm)	0.0004 in. (0.01 mm)	0.0004 in. (0.01 mm)	0.0004 in. (0.01 mm)	0.0004 in. (0.01 mm)	0.0004 in. (0.01 mm)	0.0004 in. (0.01 mm)
POWER SUPPLY REQUIREMENTS	12-24 Volts DC 20 mA, max.						
RESPONSE TIME	0.30 msec	2.00 msec	1.25 msec	1.30 msec	1.65 msec	2.00 msec	10.00 msec
OUTPUT	NPN Open Collector, max. 100 mA						
PROTECTION RATING	IEC IP67						
OUTPUT INDICATORS	LED	LED	LED	LED	LED	LED	LED
HOUSING MATERIAL	303 Stainless Steel	Nickel Plated Brass	Stainless Steel	Nickel Plated Brass	Nickel Plated Brass	Nickel Plated Brass	Nickel Plated Brass

DIMENSIONS: Self Contained Proximity Sensors

EZ Series (Threaded Body)

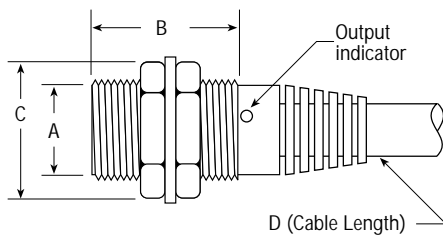

P & F Series (Threaded Body)

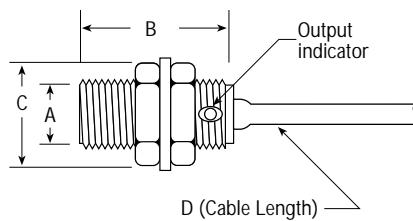

P & F 3M (Non-threaded Body)

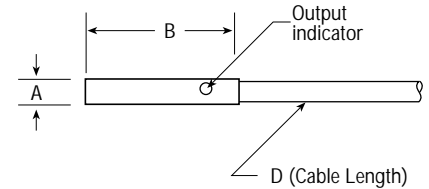

Model	A	Thread Pitch	B	C	D
P&F-3M	0.320 in. (3.00 mm)	Non Threaded	0.870 in. (22.00 mm)	N/A	6.6 ft (2 m)
P&F-8M	0.320 in. (8.00 mm)	M8, P=1	1.000 in. (25.40 mm)	0.510 in. (13.00 mm)	6.6 ft (2 m)
EZ-8M	0.320 in. (8.00 mm)	M8, P=1	0.670 in. (17.00 mm)	0.470 in. (12.00 mm)	6.6 ft (2 m)
P&F-12M	0.500 in. (12.00 mm)	M12, P=1	1.600 in. (40.00 mm)	0.670 in. (17.00 mm)	6.6 ft (2 m)
EZ-12M	0.500 in. (12.00 mm)	M12, P=1	0.790 in. (20.00 mm)	0.670 in. (17.00 mm)	6.6 ft (2 m)
P&F-18M	0.700 in. (18.00 mm)	M18, P=1	1.600 in. (40.00 mm)	0.940 in. (24.00 mm)	6.6 ft (2 m)
P&F-30M	1.180 in. (30.00 mm)	M30, P=1.5	1.600 in. (40.00 mm)	1.400 in. (36.00 mm)	6.6 ft (2 m)

Dimensions: inches (millimeters)

IMPACT SENSOR KIT

The **Impact Sensor** detects air ejected and mechanically ejected parts or parts blanked through the bolster. It detects parts as they strike the plate at velocities as low as 10 feet per second (3 meters per second). Parts may be as light as 0.01 oz (0.3 grams), about the weight of a paper clip. When a part hits the plate, the sensor sends an electrical signal to the Wintriss DiPro Sensor Interface (DSI 2).



The Impact Sensor provides a large sensing field. If necessary, you can cut the plate to get it closer to the die. In some applications, the sensor may be mounted directly to the ejection chute, provided the chute is shock mounted. Because of the time it takes the part to reach the sensor, it is typically used on presses operating at speeds lower than 175 strokes per minute.

The **Impact Sensor Kit** consists of an impact sensor with self-contained electronics mounted to a 1 x 1 ft (0.3 x 0.3 m) stainless steel plate, shockmounts, and a cable that connects to the DSI 2.

Impact Sensor Kit

With quick-connect plug

Part # 9642601

DIMENSIONS: Impact Sensor Kit

Sensor

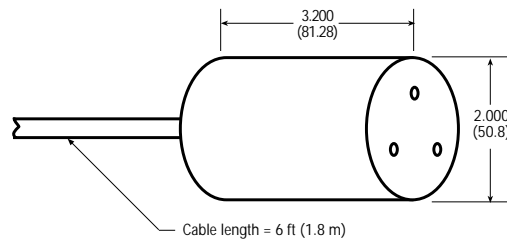

Plate

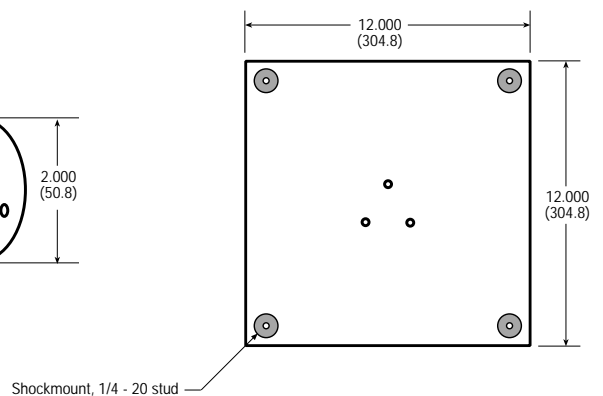

Dimensions: inches (millimeters)

DETECTALITE

The **Detectalite** senses parts as they pass through its infrared light field. It's ideal for detecting small to medium parts moving at high speeds, such as air ejected parts. Detectalite can see objects as small as 0.130 in. (3.18 mm), so it can reliably detect parts that are very thin or flat. Detectalite's advanced rejection circuitry allows it to ignore stationary objects within its field, such as chutes, brackets, etc.

Detectalite® Kit

Includes transmitter, receiver, cables and amplifier with Quick-connect plug. Requires DSI 2.

Heads - 6 in. (152.4 mm) Part # 9642301

The Detectalite kit includes a transmitter, a receiver, an amplifier and cables to connect it to the Wintriss DiPro Sensor Interface (DSI 2). Detectalite is available with a 3 in. (76.20 mm) or 6 in. (152.40 mm) high light field. The infrared light field is immune to ambient light (including fork truck strobes) and normal shop contaminants such as oil and grease.



DIMENSIONS: Detectalite

Receiver & Transmitter Heads

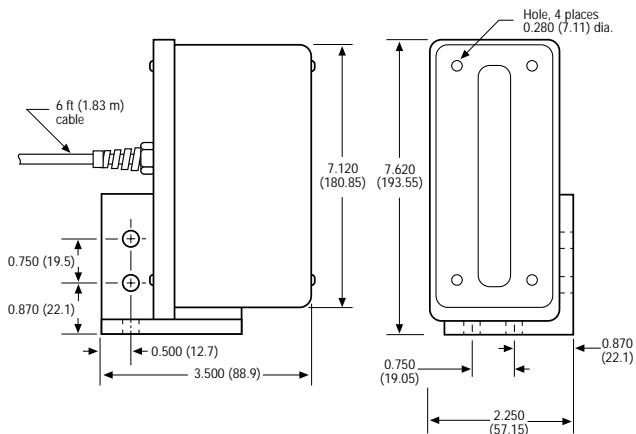

Amplifier

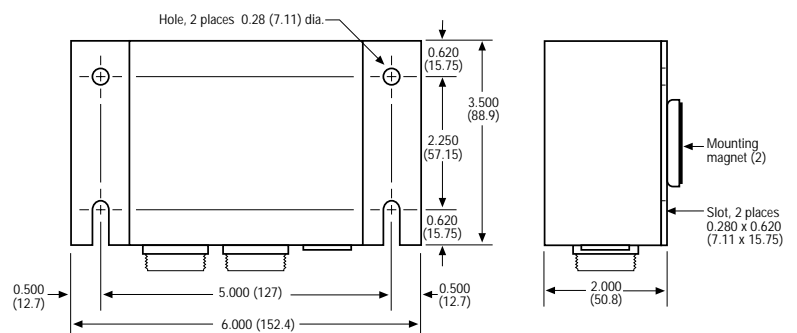

Dimensions: inches (millimeters)

ABOUT OUR COMPANY

Honeywell Wintriss Controls Group has earned ISO 9001 certification for its company-wide quality management system.

Wintriss Controls Group supplies automation and safety equipment to the metal stamping and metal forming industries, including: SmartPAC[®] programmable press automation system; die protection sensors and controls; load analyzers for machine and tool protection; and Shadow[®] Safety Light Curtains.



WINTRISS DIE PROTECTION HANDBOOK

For more detailed information on electronic sensors and die protection in general, we recommend the Wintriss Die Protection Handbook. The handbook contains over 130 pages and 150 illustrations, and is packed with information on die protection theory, sensors, applications, and die wiring. To automatically receive updates, you may register your copy of the handbook. Updates include new applications, sensor information, and tips on proper use and installation of sensors.

[Wintriss Die Protection Handbook](#)

Handbook

Part # 1097100

Honeywell

WINTRISS[®]

Honeywell Wintriss Controls Group
Sensing and Control
100 Discovery Way
Acton, Massachusetts 01720 USA

Phone: (978) 264-9550
Toll Free: (800) 586-8324
Fax: (978) 263-2491



www.wintriss.com